



*Ready to Perform  
To Your Applications*

[www.mitforklift.com.sg](http://www.mitforklift.com.sg)

© 2018 by MLAP. All Rights Reserved. All registered trademarks are the property of their respective owners. Printed in Singapore.

FMIT0144-01 (03-18)



Note: Performance specifications may vary depending on standard manufacturing tolerances, vehicle condition, types of tyres, floor or surface conditions, applications or operating environment. Trucks may be shown with non-standard options. Specific performance requirements and locally available configurations should be discussed with your Mitsubishi forklift truck dealers. Mitsubishi Forklift Trucks follows a policy of continual product improvement. For this reason, some materials, options and specifications could change without notice.

PRESENTED BY :



**FD70-100NH TRUCK 7.0 – 10.0 TON**

# THE PURTY OF POWER

## ROBUST PERFORMANCE

### The Mitsubishi FD70-100NH

*truck pulsates with pristine power. It is a fact so simple and yet so remarkable: a truck that powers pure performance. Built for load capacities of 7.0 to 10.0 tons, the heart of the truck's rugged performance lies in its solid Isuzu 6BG1 direct-injection 6.5-litre diesel engine. With an output of 82.4kW (112ps / 2000rpm)—a top industry achievement—this impressive truck promises unrivalled excellent performance in harsh outdoor environments subjected to changing seasons and inclement conditions.*

⚡ <b>FD70NH</b> ⚡	LIFT SPEED	with load	mm/s	460
		without load	mm/s	550

### Strong and Swift

Driven by one of the most powerful engines in its class, the FD70-100NH boasts both strength and speed. The massive loads it can handle do not hamper its speed, making it one of the fastest and most efficient of machines in the industry.

\*The value is for FD70NH

### Rigid Wide View Mast

The truck's strong and rigid mast is complemented by a thoughtful layout of end and side rollers that reduces swaying and enhances stability. The mast system ensures strength and durability through inner mast channels with a greater cross section and more rollers than most models. These multiple adjustable rollers pervade the inner mast channels, providing intricate balance for managing side and off-centre loads, improving overall efficiency and performance.

### Durable mast with a thoughtful layout of rollers

- The inner mast channels have a greater cross section and a larger number of rollers than our competitors' mast do, thus ensuring great strength and durability.
- The side loads on the lift bracket are carried by both the side and retaining rollers on both sides of the inner mast channels, to reduce the possibility of wear on the mast channels and to handle off-centre loads.
- The mast and lift bracket on the cab can be adjusted using only the side rollers. The inner channels and lift brake do not have to be removed.

### Strong, Rigid Mast



# SUPERIOR SAFETY

# PRIME PRODUCTIVITY

## ▶ Smooth Transmission and An Electric Shift Lever

A dual-speed automatic transmission makes it easy to accelerate smoothly to top speeds via a pedal without manual gear changes, providing instant manoeuvrability. A simple electric shift lever that guides direction changes effectively whilst handling loads deftly.

## ▶ Parking Brake: Enhanced Safety

The parking brake lever is equipped with a safety device that can only be released by pushing a button on the lever tip. This double-action release improves safety, unlike the single-action toggle parking brakes found on conventional models, which is prone to accidental release by an operator's entry into and exit from the truck.

## ▶ Travel Hydraulic Interlock

For superior safety, the truck's standard operator-presence system features seat-actuated power interruption that locks all travel and hydraulics when the operator is not seated in the truck. Effective only on flat terrain (not on slopes), this sensitive power-severance feature takes truck safety to the next level.

### OPERATOR IS NOT SEATED

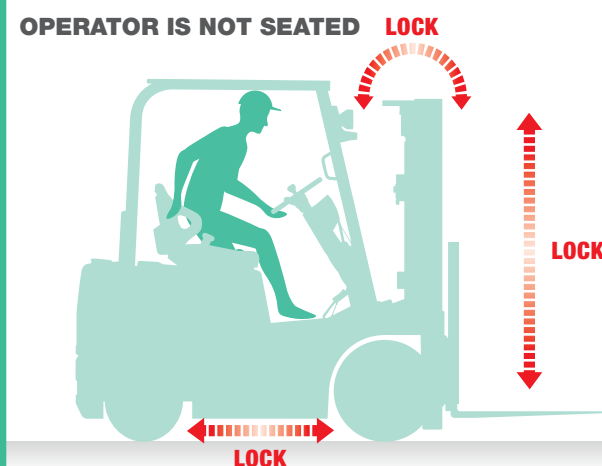

### OPERATOR IS SEATED



## ▶ LED Lights

LED lights are standard features for the rear combination lights, head lights, and turn signal lights. These high-quality bright lights are energy saving, durable, cooler, and sturdier, promising to be an effective aid to overall total cost of ownership.

## Comfort

The FD70-100NH ticks all the boxes for user comfort. User conveniences include a glove compartment for holding either a pair of gloves or a beverage can as well as a separate pen holder—for easy placement and retrieval.

Characteristics					
Model			FD70NH	FD80NH	FD100NH
Capacity	Q	kg	7000	8000	10000
Load Centre	C	mm	600	600	600
Power source: (battery, diesel, LPG, petrol)			Diesel	Diesel	Diesel
Operator type: pedestrian, (operator)-standing, -seated			Seated	Seated	Seated
Dimensions					
Lift height	$h_3$	mm	3000	3000	3000
Free lift	$h_2$	mm	215	205	205
Fork dimensions (length, width, thickness)	$L_1/B_1/S$	mm	1220 x 150 x 70	1220 x 170 x 75	1220 x 180 x 75
Tilt Angle (forward/backward)	$\partial/\beta$	°	6/12	6/12	6/12
Length to fork face (includes fork thickness)	$L_2$	mm	3600	3940	4255
Overall width	B	mm	1995	2165	2245
Height with mast lowered	$h_1$	mm	2500	2700	2850
Overall height with mast raised	$h_4$	mm	4420	4420	4330
Height to top of overhead guard	$h_6$	mm	2450	2560	2560
Load distance, axle to fork face	X	mm	625	720	710
Performance					
Travel speed, with/without load		km/h	26.0 / 30.0	25.0 / 30.0	24.0 / 30.0
Lifting speed, with/without load		mm/s	460/ 550	450/ 470	390/ 410
Lowering speed, with/without load		mm/s	450/ 500	450/ 450	470/ 340
Rated drawbar pull, with/without load		N	52900 / 21600	57300 / 27400	57300 / 31400
Gradeability Max, with/without load		%	29 / 19	27 / 19	22 / 20
Turning radius	Wa	mm	3360	3650	3900
Right Angle Stacking Isle Width	Ast 4	mm	5620	6015	6250
Weight					
Truck weight, without load		kg	9360	10980	12300
Axle loading with maximum load, front/rear		kg	14530 / 1830	17040 / 1940	20100 / 2200
Axle loading without load, front/rear		kg	3750 / 5610	4820 / 6160	5420 / 6880
Wheels, Chassis					
Tyres ( front/rear)			Pneumatic/Pneumatic	Pneumatic/Pneumatic	Pneumatic/Pneumatic
Number of wheels, front/rear (x=driven)			4x / 2	4x / 2	4x / 2
Tyre dimensions, front			8.25X15-14PR	9.00X20-14PR	9.00X20-14PR
Tyre dimensions, rear			8.25X15-14PR	9.00X20-14PR	9.00X20-14PR
Wheelbase	Y	mm	2250	2500	2800
Tread width (centre of tyres), front		mm	1470	1600	1600
Tread width (centre of tyres), rear		mm	1700	1700	1700
Ground clearance under mast (lowest point)		mm	190	245	245
Ground clearance at centre of frame			230	335	335
Brake					
Parking brake			Hand/ Mechanical	Hand/ Mechanical	Hand/ Mechanical
Service brake			Foot/ Hydraulics	Foot/ Hydraulics	Foot/ Hydraulics
Powertrain					
Manufacturer / Type			Isuzu 6BG1	Isuzu 6BG1	Isuzu 6BG1
Rated output (JIS112)		kW/rpm	82.4/ 2000	84.6/ 2100	84.6/ 2100
Max torque (JIS42.5)		Nm/rpm	416.5/1500	416.5/1500	416.5/1500
Number of cylinders / cubic capacity		cm <sup>3</sup>	6 / 6494	6 / 6494	6 / 6494
Type of drive control (Number of gears, forward/reverse)			Powershift 2/2	Powershift 2/2	Powershift 2/2
Maximum operating pressure for attachments		Mpa (kgf/cm <sup>2</sup> )	19.6 (200)	19.6 (200)	19.6 (200)
Battery (Number x Volts - Ampere hrs)			2 x 12V-70Ah/20h	2 x 12V-70Ah/20h	2 x 12V-70Ah/20h
Noise level, value at operator's ear (EN 12053)		dB(A)	85	85	85

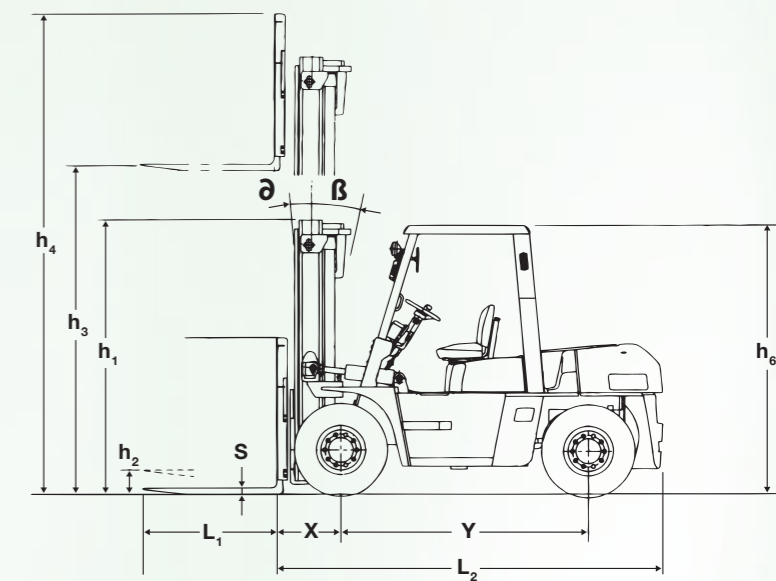
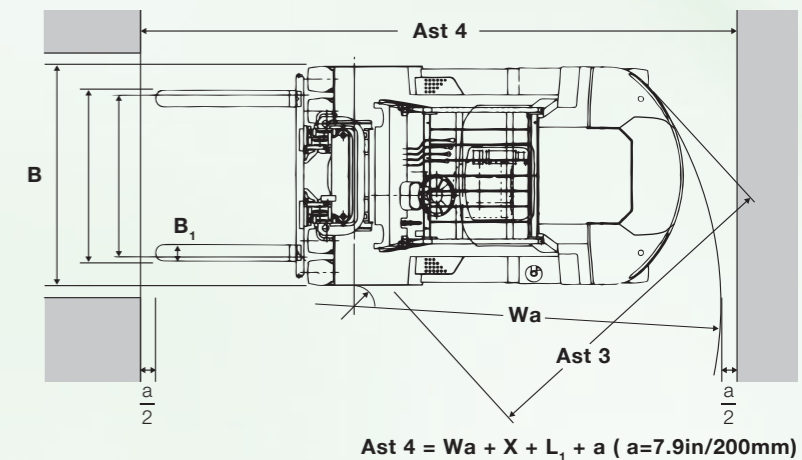

OPTIONAL

## All-weather Covered Steel Cabin



Ergonomic driver workspaces have increasingly become one of the most important criteria in purchasing forklift trucks. As an option, the FD70-100NH offers a rugged all-weather covered steel cabin suitable for operating in unfavourable and challenging environments or with exposure to seasonal elements and inclement weather.



Other optional items include the windshield and wiper as well as air-conditioning and heating units. These ergonomic aspects promise an overall comfortable, convenient and safe working space for truck operators.